

User's Guide

NHD-0116GZ-NSPG-FBW

LCM

(Liquid Crystal Display Module)

RoHS Compliant

- NHD-** Newhaven Display
- 0116-** 1 Lines x 16 Characters
- GZ-** Version Line
- N -** Transmissive
- SPG-** Side Pure Green LED B/L
- F-** FSTN (-)
- B-** 6:00 View
- W-** Wide Temperature (-20 ~ +70c)

For product support, contact

Newhaven Display International, LLC
2511 Technology Drive, #101
Elgin, IL 60124
Tel: (847) 844-8795 Fax: (847) 844-8796

October 2, 2007

Outline Dimension

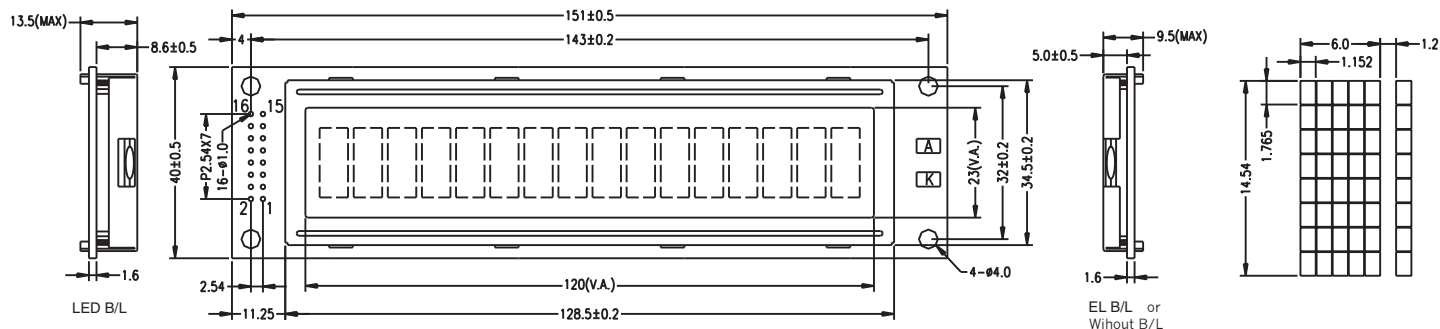

Feature

1. 5x8 dots with cursor
2. Built-in controller (KS0066U or Equivalent)
3. +5V power supply (Also available for +3.0V)
4. 1/16 duty cycle
5. BKL to be driven by pin1, pin2, or pin15, pin16 or A, K
6. N.V. optional

Interface pin connections

PIN NO	Symbol	Function
1	VSS □	GND
2	VDD □	+5V
3	V0	Contrast adjustment
4	RS	H/L Register select signal
5	R/W □	H/L Read/Write signal
6	E	H/L Enable signal
7	DB0 □	H/L Data bus line
8	DB1 □	H/L Data bus line
9	DB2 □	H/L Data bus line
10	DB3 □	H/L Data bus line
11	DB4 □	H/L Data bus line
12	DB5 □	H/L Data bus line
13	DB6 □	H/L Data bus line
14	DB7 □	H/L Data bus line
15	A	+4.2V for BKL
16	K	Power supply for BKL(0V)

Mechanical Data

Item	Standard	Unit
Module dimension	151.0x40.0	mm
Viewing area	120.0x23.0	mm
Dot size	1.152x1.765	mm
Character size	6.00x14.54	mm

Absolute Maximum Rating

Item	Symbol	Standard			Unit
		Min	Typ	Max	
Power supply	VDD-VSS	-0.3	-----	5.5	V
Input voltage	VI	-0.3	-----	VDD	

Electrical characteristics

Item	Symbol	Condition	Standard			Unit
			Min	Typ	Max	
Input voltage	VDD	+5V	4.7	5.0	5.5	V
		+3.3V	2.7	3.0	5.3	V
Supply current	I _{DD}	VDD=5V	-----	2	4	mA
Recommended LCD driving voltage for normal temp version module	VDD-V0	-20°C	-----	-----	-----	V
		0 °C	4.7	5.0	5.5	
		25°C	4.3	4.5	4.7	
		50°C	4.1	4.3	4.5	
LED forward voltage	VF	25°C	-----	4.2	4.6	V
LED forward current	IF	25°C	-----	300	-----	mA
EL power supply current	I _{EL}	V _{EL} =110V AC 400Hz	-----	-----	-----	mA

Display character address code:

Display position
 1 2 3 4 5 6 7 8 9 10 11 12 13 14 15 16
 DDRAM address 00 01 02 --- --- --- 40 41 42 --- --- --- 47H

Absolute Maximum Ratings

Item	Symbol	Min	Max	Unit
Power Voltage	$V_{DD} - V_{SS}$	0	7.0	V
Input Voltage	V_{in}	V_{SS}	V_{DD}	
Operating Temperature Range	T_{OP}	-20	+70	°C
Storage Temperature Range	T_{ST}	-30	+80	

*Wide Temperature range is available (operating/storage temperature as wide as -20 ~ +70/-30 ~ +80°C)。

Description Of Terminals

Pin No.	Pin Name	Input/ Output	External Connection	Function
1	VSS	—	Power Supply	VSS:GND
2	VDD	—		VDD: +5V
3	VO	—		V_{LCD} adjustment
4	RS	INPUT	MPU	Register select signal "0":Instruction register (when writing) Busy flag & address counter (When reading) "1":Data register (when writing & reading)
5	R/W	Input	MPU	Read/write select signal "0" for writing , "1" for reading
6	E	Input	MPU	Operation (data read/write) enable signal
7 / 10	DB0-DB3	Input	MPU	Low-order lines of data bus with 3-state, bi-directional function for use in data transaction with the MPU. These lines are not used when interfacing with a 4-bit microprocessor.
11 / 14	DB4-DB7	Input	MPU	High-order lines of data bus with 3-state, bi-directional function for use in data transactions with the MPU. DB7 may also be used to check the busy flag.
15 / 16	LED " +" LED " -"	Input	LED BACKLIGHT POWER SUPPLY	LED" +" VOLTAGE TYPE:4.2V MAX : 4.5V LED" -" : GND

Optical Characteristics

for TN Type Display Module ($T_a=25^{\circ}\text{C}$, $V_{DD}=5.0\text{V}\pm 0.25\text{V}$)

Item	Symbol	Condition	Min.	Typ.	Max.	Unit
Viewing angle	θ	$C_r \geq 4$	-25	-	-	deg
	ϕ		-30	-	30	
Contrast ratio	C_r		-	2	-	-
Response time (rise)	T_r	-	-	120	150	ms
Response time (fall)	T_r	-	-	120	150	ms

for STN Type Display Module ($T_a=25^{\circ}\text{C}$, $V_{DD}=5.0\text{V}\pm 0.25\text{V}$)

Item	Symbol	Condition	Min.	Typ.	Max.	Unit
Viewing angle	θ	$C_r \geq 2$	-60	-	35	deg
	ϕ		-40	-	40	
Contrast ratio	C_r		-	6	-	-
Response time (rise)	T_r	-	-	150	250	ms
Response time (fall)	T_r	-	-	150	250	ms

Electrical Characteristics

DC Characteristics

Parameter	Symbol	Conditions	Min.	Type	Max.	Unit
Supply voltage for LCD	$V_{DD} - V_O$	$T_A=25^{\circ}\text{C}$	—	4.6	—	V
Input voltage	V_{DD}		4.7	—	5.5	V
Supply current	I_{DD}	$V_{DD}=5.0\text{V}; T_A=25^{\circ}\text{C}$	—	1.5	2.5	mA
Input leakage current	I_{LKG}		—	—	1.0	μA
"H" level input voltage	V_{IH}		2.2	—	V_{DD}	V
"L" level input voltage	V_{IL}	Twice initial value or less	0	—	0.6	V
"H" level output voltage	V_{OH}	$LOH = -0.25\text{MA}$	2.4	—	—	V
"L" level output voltage	V_{OL}	$LOL = 1.6\text{MA}$	—	—	0.4	V

AC Characteristics

Read Cycle ($V_{DD}=5.0V+10\%$, $V_{SS}=0V$, $T_a=25^\circ C$)

Parameter	Symbol	Test pin	Min.	Type	Max.	Unit
Enable cycle time	t_c	E	500	-	-	ns
Enable pulse width	t_w	E	300	-	-	
Enable rise/fall time	t_r, t_f	E	-	-	25	
RS,R/W setup time	t_{su}	RS; R/W	100	-	-	
RS,R/W address hold time	t_h	RS; R/W	10	-	-	
Read data output delay	t_D	DB0-DB7	60	-	190	
Read data hold time	t_{DH}	DB0-DB7	20	-	-	

Write Cycle

Parameter	Symbol	Test pin	Min.	Type	Max.	Unit
Enable cycle time	t_c	E	500	-	-	ns
Enable pulse width	t_w	E	300	-	-	
Enable rise/fall time	t_r, t_f	E	-	-	25	
RS,R/W setup time	t_{su1}	RS; R/W	100	-	-	
RS,R/W address hold time	t_{h1}	RS; R/W	10	-	-	
Data setup time	t_{su2}	DB0-DB7	60	-	-	
Data hold time	t_{h2}	DB0-DB7	10	-	-	

Timing Characteristics

Write Timing

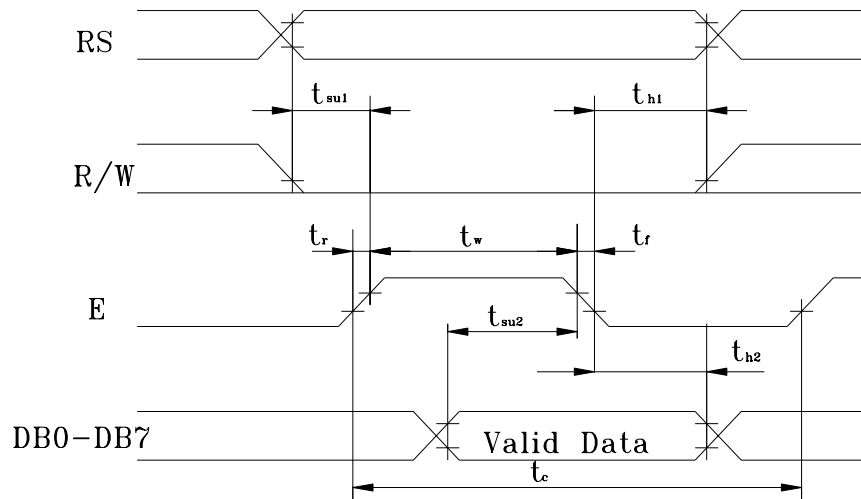

Read Timing

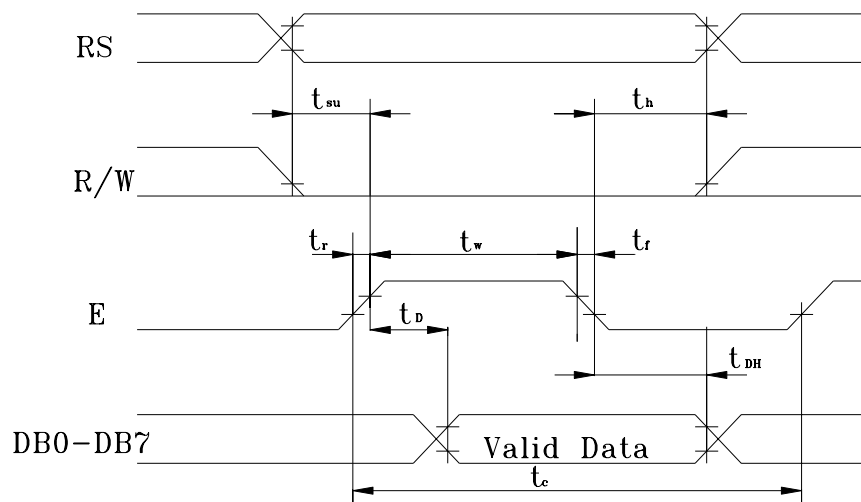

Block Diagram

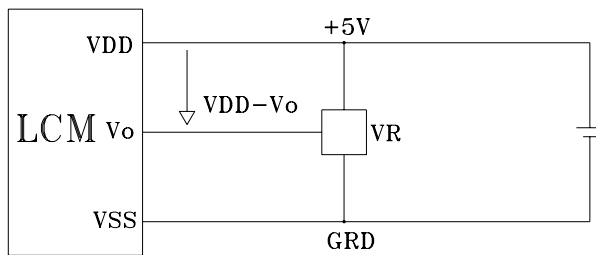
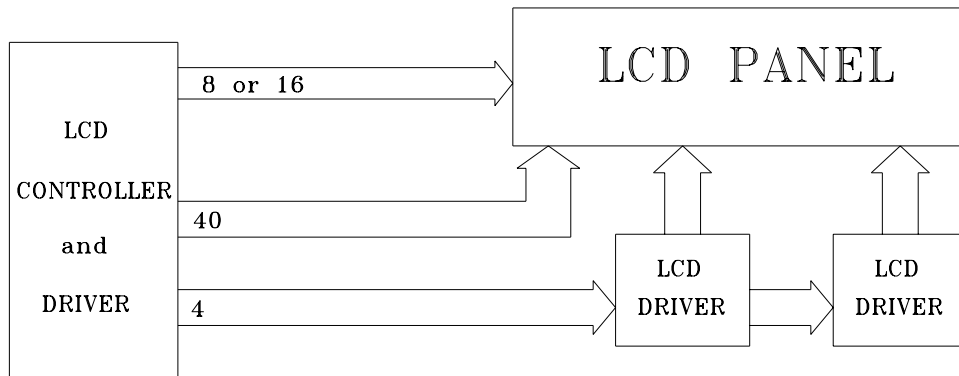

VDD-Vo: LCD DRIVING VOLTAGE

VR: 10K-20K Ω

Display Command

Parameter	RS	R/W	DB7	DB6	DB5	DB4	DB3	DB2	DB1	DB0	Note	Executing time fosc=250kh z
Clear Display	0	0	0	0	0	0	0	0	0	1		1.64ms
Cursor home	0	0	0	0	0	0	0	0	1	*		1.64ms
Entry Mode Set	0	0	0	0	0	0	0	1	1/D	S	DB1=1:Increment DB1=0:Decrement DB0=1:The display is shifted DB0=0:The display is not shifted	40μ s
Display on/off	0	0	0	0	0	0	1	D	C	B	DB2=1:Display on DB2=0: Display off DB1=1:Cursor on DB1=0: Cursor off DB0=1:Brinking on DB0=0:Brinking off	40μ s
Cursor / Display Shift	0	0	0	0	0	1	S/C	R/L	*	*	DB3=1:Shifts display one character DB2=1:Right shift DB2=0:Left shift	40μ s
System Set	0	0	0	0	1	DL	N	F	*	*	DB4=1:8 bits DB4=0:4 bits DB3=1:2 lines display (1/16 duty) DB3=0:1 line display DB2=1:5×10 dots , 1/11 duty DB2=1:5 × 7 dots , 1/8 duty	40μ s
Set CG RAM Address	0	0	0	1	CG RAM address corresponds to cursor address						The address length that can be set is 64 address	40μ s
Set DD RAM Address	0	0	1	DD RAM address						The address length that can be set is 80 address	40μ s	
Read Busy Flug/Address Counter	0	1	BF	Address counter used for both DD&CG RAM address						DB7=1:Busy (instruction not accepted) DB7=0:Ready(for instruction)	40μ s	
Write Data	1	0	Write data									46μ s
Read Data	1	1	Read data									46μ s

DD RAM Address:

	1	2	3	4	5	6	7	8	9	10	11	12	13	14	15	16
Address for line	00	01	02	03	04	05	06	07	40	41	42	43	44	45	46	47

Reliability and Life Time

1. Reliability Test

Storage Condition	Content	Evaluations and Assessment*			
		Current consumption	Oozing	Contrast	Other appearances
Operation at high temperature and humidity	40°C,90% RH,240hrs	Twice initial value or less	none	More than 80% of initial value	No abnormality
High temperature storage	60°C, 240hrs	Twice initial value or less	none	More than 80% of initial value	No abnormality
Low temperature storage	-20°C, 240hrs	Twice initial value or less		More than 80% of initial value	No abnormality

*Evaluations and assessment to be made two hours after returning to room temperature (25°C±5°C).

*The LCDs subjected to the test must not have dew condensation.

2. Liquid crystal panel service life

50,000 hours minimum at 25±10°C,45±20%RH.

Standard Character Pattern

Lower 4 Bits \ Upper 4 Bits	0000	0001	0010	0011	0100	0101	0110	0111	1000	1001	1010	1011	1100	1101	1110	1111
xxxx0000	CG RAM (1)			0	a	P	`	P				-	夕	三	α	ρ
xxxx0001	(2)		!	1	A	Q	a	q			。	ア	チ	△	△	q
xxxx0010	(3)		"	2	B	R	b	r			「	イ	ツ	×	ρ	θ
xxxx0011	(4)		#	3	C	S	c	s			」	ウ	テ	モ	ε	ω
xxxx0100	(5)		\$	4	D	T	d	t			、	エ	ト	ト	μ	Ω
xxxx0101	(6)		%	5	E	U	e	u			・	オ	ナ	1	ε	ü
xxxx0110	(7)		&	6	F	V	f	v			ヲ	カ	ニ	ヨ	ρ	Σ
xxxx0111	(8)		'	7	G	W	g	w			ア	キ	ヌ	ラ	g	π
xxxx1000	(1)		(8	H	X	h	x			イ	ク	ネ	リ	ρ	Σ
xxxx1001	(2))	9	I	Y	i	y			ウ	ケ	ル	ル	ρ	γ
xxxx1010	(3)		*	:	J	Z	j	z			エ	コ	ン	レ	j	≠
xxxx1011	(4)		+	;	K	[k	[オ	サ	ヒ	ロ	*	≠
xxxx1100	(5)		,	<	L	¥	l	l			カ	シ	フ	ワ	≠	≠
xxxx1101	(6)		-	=	M]	m]			ユ	ス	ハ	ン	≠	÷
xxxx1110	(7)		.	>	N	^	n	+			ヨ	セ	ホ	°	≠	
xxxx1111	(8)		/	?	O	_	o	+			ッ	ソ	マ	°	ö	■

Note: The user can specify any pattern for character-generator RAM.